

Current Transducer LF 2005-S/SP21

For the electronic measurement of currents: DC, AC, pulsed..., with galvanic separation between the primary circuit and the secondary circuit.

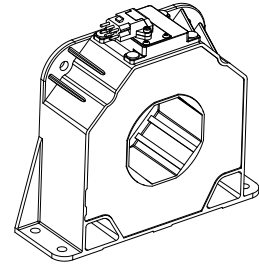

$$I_{PN} = 2000 \text{ A}$$



Electrical data

I_{PN}	Primary nominal RMS current	2000	A			
I_{PM}	Primary current, measuring range @ $\pm 24 \text{ V}$	0 ... ± 3500	A			
\hat{I}_{Pmax}	Primary withstand peak current (maximum)	20 ¹⁾	kA			
R_M	Measuring resistance	with $\pm 15 \text{ V}$	@ $\pm 2000 \text{ A}_{max}$	R_{Mmin}	R_{Mmax}	
			@ $\pm 2500 \text{ A}_{max}$	0	8	Ω
		with $\pm 24 \text{ V}$	@ $\pm 2000 \text{ A}_{max}$	0	3	Ω
			@ $\pm 2000 \text{ A}_{max}$	5	25	Ω
			@ $\pm 3500 \text{ A}_{max}$	5	7	Ω
I_{SN}	Secondary nominal RMS current	500	mA			
N_P/N_S	Turns ratio	1 : 4000				
U_C	Supply voltage ($\pm 5 \%$)	$\pm 15 \dots 24$	V			
I_C	Current consumption	33 (@ $\pm 24 \text{ V}$) + I_S	mA			

Accuracy - Dynamic performance data

ϵ_{tot}	Total error @ $I_{PN}, T_A = 25 \text{ }^\circ\text{C}$	± 0.4	%
ϵ_L	Linearity error	< 0.1	%
		Max	
I_O	Offset current @ $I_P = 0, T_A = 25 \text{ }^\circ\text{C}$	± 1.0	mA
I_{OM}	Magnetic offset current @ $I_P = 0$ and specified R_M , after an overload of $3 \times I_{PN}$	± 0.2	mA
I_{OT}	Temperature variation of I_O $-40 \text{ }^\circ\text{C} \dots +85 \text{ }^\circ\text{C}$	± 0.8	mA
t_{D90}	Delay time to 90 % of the final output value for I_{PN} step ²⁾ < 1		μs
BW	Frequency bandwidth (-1 dB)	DC ... 100	kHz

General data

T_A	Ambient operating temperature	$-40 \dots +85$	$^\circ\text{C}$
T_{Ast}	Ambient storage temperature	$-45 \dots +85$	$^\circ\text{C}$
R_S	Resistance of secondary winding @ $T_A = 85 \text{ }^\circ\text{C}$	17	Ω
m	Mass	1.6	kg
	Standards	EN 50155: 2017 ³⁾ EN 50121-3-2: 2016	

Notes: ¹⁾ Once daily
²⁾ For a $di/dt = 100 \text{ A}/\mu\text{s}$
³⁾ Additional information available on request.

Features

- Closed loop (compensated) current transducer using the Hall effect
- Insulating plastic case recognized according to UL 94-V0.

Special features

- $N_P/N_S = 1 : 4000$
- $U_d = 12 \text{ kV}$
- $T_A = -40 \text{ }^\circ\text{C} \dots +85 \text{ }^\circ\text{C}$
- Shield
- Connection to secondary circuit on SMS6GE6
- Customer marking Alstom N° DTR0000024346.

Advantages

- Excellent accuracy
- Very good linearity
- Low temperature drift
- Optimized response time
- Wide frequency bandwidth
- No insertion losses
- High immunity to external interference
- Current overload capability.

Applications

- Single or three phase inverters
- Propulsion and braking chopper
- Propulsion converter
- Auxiliary converter
- Battery charger.

Application Domain

- Railway (fixed installations and onboard).

Current Transducer LF 2005-S/SP21

Insulation coordination

U_d	RMS voltage for AC insulation test, 50 Hz, 1 min	12 ¹⁾	kV
		1 ²⁾	kV
U_t	Partial discharge RMS test voltage ($q_m < 10$ pC)	≥ 4.8 ³⁾	kV
		Min	
d_{cp}	Creepage distance	78.6	mm
d_{cl}	Clearance	59.21	mm
CTI	Comparative tracking index (group I)	600	

Notes: ¹⁾ Between primary and secondary
²⁾ Between secondary and shield
³⁾ With a non insulated primary bar, diameter 40 mm centered in the through-hole.

Safety

This transducer must be used in limited-energy secondary circuits according to IEC 61010-1.



This transducer must be used in electric/electronic equipment with respect to applicable standards and safety requirements in accordance with the manufacturer's operating instructions.



Caution, risk of electrical shock

When operating the transducer, certain parts of the module can carry hazardous voltage (eg. primary busbar, power supply).

Ignoring this warning can lead to injury and/or cause serious damage.

This transducer is a build-in device, whose conducting parts must be inaccessible after installation.

A protective housing or additional shield could be used.

Main supply must be able to be disconnected.

Dimensions LF 2005-S/SP21 (in mm)

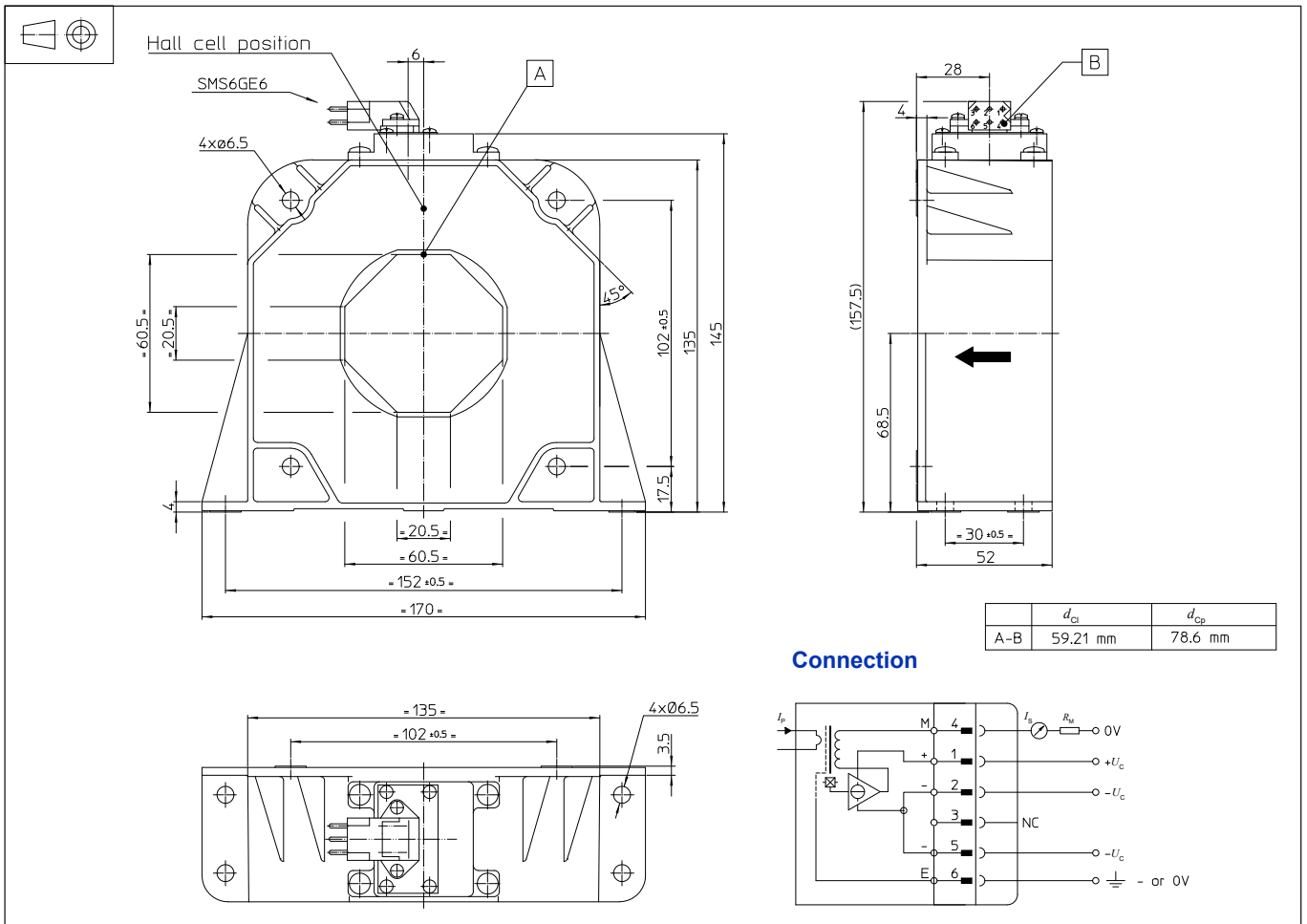

Mechanical characteristics

- General tolerance ± 1 mm
- Transducer fastening 4 holes \varnothing 6.5 mm
Vertical or flat lying position 4 M6 steel screws
Recommended fastening torque 4.2 Nm
- Primary through-hole 60.5 x 20.5 mm
Or \varnothing max 56 mm
- Connection of secondary SMS6GE6

Remarks

- I_s is positive when I_p flows in the direction of the arrow.
- Temperature of the primary conductor should not exceed 100 °C.
- Installation of the transducer must be done unless otherwise specified on the datasheet, according to LEM Transducer Generic Mounting Rules. Please refer to LEM document N°ANE120504 available on our Web site: <https://www.lem.com/en/file/3137/download/>.
- Dynamic performances (di/dt and delay time) are best with a single bar completely filling the primary hole.